

# EDH

## Stainless Steel Horizontal Multistage Pump



### Application

- It is applicable to household water supply, equipment support, pipeline pressurization, garden watering, vegetable greenhouse watering, fish farming and poultry raising, industrial and mining, water supply and drainage of enterprises and high-rise buildings, central air conditioner and centralized heating circulation system, etc.

### Pump

- AISI 304 shaft
- Max. liquid temperature: +85°C
- Altitude: up to 1000 m
- Max. suction: 8 m
- Max. inlet pressure: limited by max. operating pressure
- Max. operation pressure: 10 bar
- Liquid PH value: 4 - 10

### Motor

- IE2 motor (IE3 motor available on request)
- Motor with copper winding
- Built-in thermal protector for single phase motor
- Insulation class: F
- Protection class: IP55
- Max. ambient temperature: +40°C

### Identification Codes

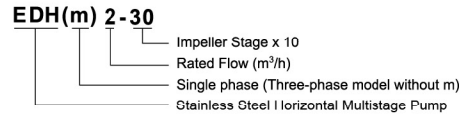

### Technical Data

Model	Power (P2)		Q (m <sup>3</sup> /h)	0.5	1.0	1.5	2.0	2.5	3.0	3.5	4.0
	kW	HP									
EDH(m)2-20	0.37	0.5	H (m)	16.7	16.2	15	14	11	10.6	8.8	6.5
EDH(m)2-30	0.37	0.5		25.8	24.3	23.8	21.3	17	16.1	12.5	7.2
EDH(m)2-40	0.55	0.75		34.8	34.1	33.2	30.7	23	22.9	18.4	12.6
EDH(m)2-50	0.55	0.75		43.5	42.1	30.5	35.0	20	25.7	10.6	13.5
EDH(m)2-60	0.75	1.0		50.8	49.2	45.6	41.5	35	30.4	23.4	14.3

### Dimension

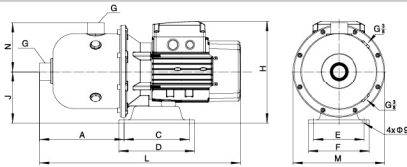

Model	L	A	C	D	E	F	G	H	J	M	N
EDH(m)2-20	427	180	138	160	108	130	G1	216	110	Φ195	103
EDH(m)2-30	427	180	138	160	108	130	G1	216	110	Φ195	103
EDH(m)2-40	427	180	138	160	108	130	G1	216	110	Φ195	103
EDH(m)2-50	427	180	138	160	108	130	G1	216	110	Φ195	103
EDH(m)2-60	427	180	138	160	108	130	G1	216	110	Φ195	103

### Hydraulic Performance Curves

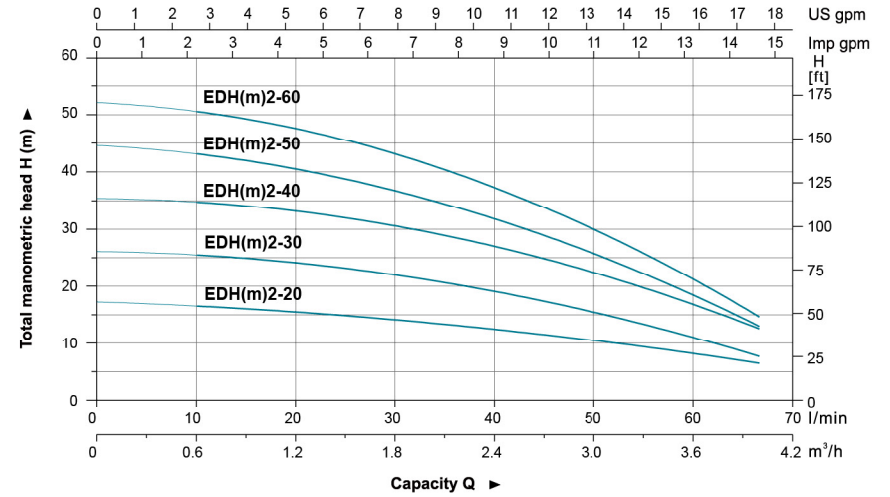

### Materials Table

No.	Part	Material
1	Pump body	AISI 304
2	Support	ZL102
3	Bottom plate	Cast iron
4	Stator	
5	Rotor	
6	Bearing	
7	Rear cover	ZL102
8	Fan	PP
9	Fan cover	08F
10	Bracket cover	AISI 304
11	Mechanical seal	SiC/Carbon
12	Positioning sleeve	AISI 304
13	Diffuser 3	AISI 304
14	Diffuser 2	AISI 304
15	Sleeve	AISI 304
16	Impeller	AISI 304
17	Diffuser 1	AISI 304
18	Pressure plate	AISI 304
19	Spacer bush	AISI 304

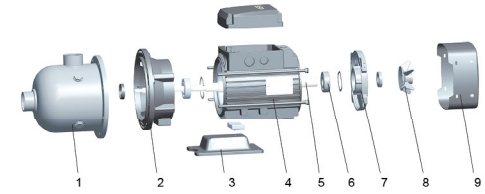
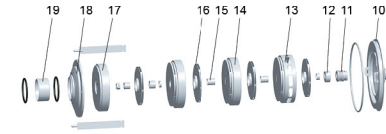

### Package Information

Model	GW (Kgs)	L (mm)	W (mm)	H (mm)	Quantity (PCS/20' TEU)
EDH(m)2-20	10.7	465	225	270	1044
EDH(m)2-30	11.1	465	225	270	1044
EDH(m)2-40	12.4	465	225	270	1044
EDH(m)2-50	12.8	465	225	270	1044
EDH(m)2-60	13.8	465	225	270	1044

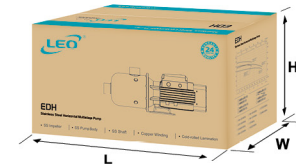

# EDH

## Stainless Steel Horizontal Multistage Pump

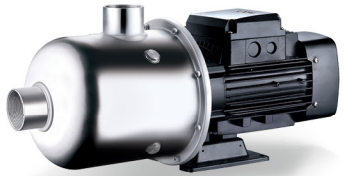

### Application

- It is applicable to household water supply, equipment support, pipeline pressurization, garden watering, vegetable greenhouse watering, fish farming and poultry raising, industrial and mining, water supply and drainage of enterprises and high-rise buildings, central air conditioner and centralized heating circulation system, etc.

### Pump

- AISI 304 shaft
- Max. liquid temperature: +85°C
- Altitude: up to 1000 m
- Max. suction: 8 m
- Max. inlet pressure: limited by max. operating pressure
- Max operation pressure: 10 bar
- Liquid PH value: 4 - 10

### Motor

- IE2 motor (IE3 motor available on request)
- Motor with copper winding
- Built-in thermal protector for single phase motor
- Insulation class: F
- Protection class: IP55
- Max. ambient temperature: +40°C

### Identification Codes

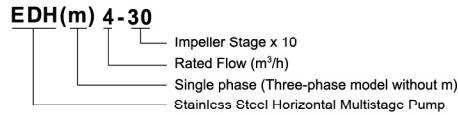

### Technical Data

Model	Power (P2)		Q (m <sup>3</sup> /h)	1.0	2.0	3.0	4.0	4.5	5.0	6.0	7.0
	kW	HP		Q (l/min)	17	33	50	67	75	83	100
EDH(m)4-20	0.55	0.75	H (m)	17.8	17.2	16.1	14.3	12	11.3	6.3	2.3
EDH(m)4-30	0.55	0.75		26.7	26.4	24.6	22.1	18	16.8	13.5	7.3
EDH(m)4-40	0.75	1.0		36.1	35.2	32.9	29.9	25	24.7	18.6	9.2
EDH(m)4-50	1.1	1.5		45.7	43.6	40.5	37	32	31.8	21.8	10
EDH(m)4-60	1.1	1.5		53.6	52	47	42.5	37	35	23	12

### Dimension

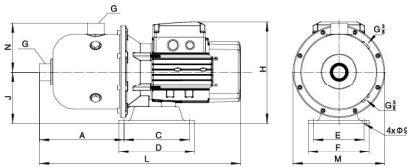

Model	L	A	C	D	E	F	G	H	J	M	N
EDH(m)4-20	427	180	138	160	108	130	G <sub>1 1/2</sub>	216	110	Φ195	103
EDH(m)4-30	427	180	138	160	108	130	G <sub>1 1/2</sub>	216	110	Φ195	103
EDH(m)4-40	427	180	138	160	108	130	G <sub>1 1/2</sub>	216	110	Φ195	103
EDH(m)4-50	480	180	138	160	108	130	G <sub>1 1/2</sub>	245	120	Φ195	103
EDH(m)4-60	480	180	138	160	108	130	G <sub>1 1/2</sub>	245	120	Φ195	103

### Hydraulic Performance Curves

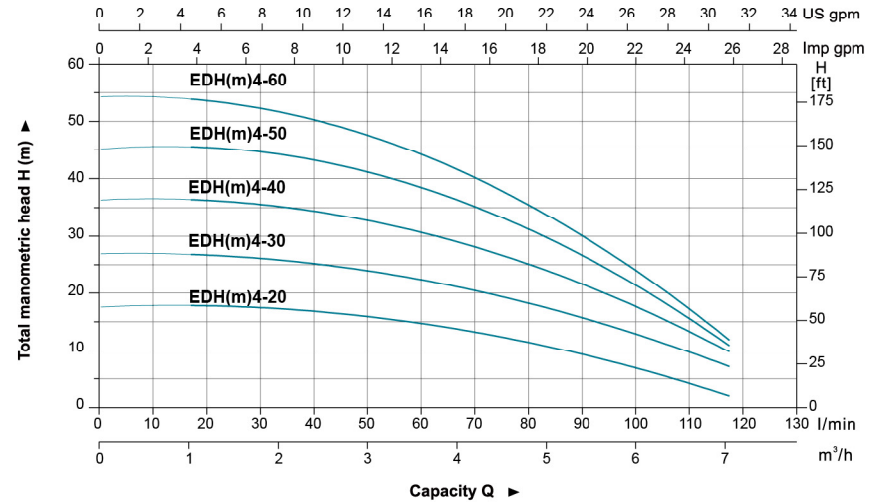

### Materials Table

No.	Part	Material
1	Pump body	AISI 304
2	Support	ZL102
3	Bottom plate	Cast iron
4	Stator	
5	Rotor	
6	Bearing	
7	Rear cover	ZL102
8	Fan	PP
9	Fan cover	08F
10	Bracket cover	AISI 304
11	Mechanical seal	SiC/Carbon
12	Positioning sleeve	AISI 304
13	Diffuser 3	AISI 304
14	Diffuser 2	AISI 304
15	Sleeve	AISI 304
16	Impeller	AISI 304
17	Diffuser 1	AISI 304
18	Pressure plate	AISI 304
19	Spacer bush	AISI 304

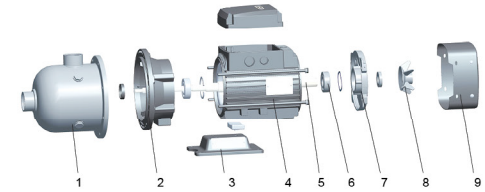
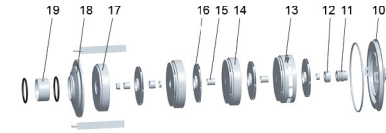

### Package Information

Model	GW (Kgs)	L (mm)	W (mm)	H (mm)	Quantity (PCS/20 TEU)
EDH(m)4-20	11.5	465	225	270	1044
EDH(m)4-30	12.9	465	225	270	1044
EDH(m)4-40	13.8	465	225	270	1044
EDH(m)4-50	18.2	515	225	297	870
EDH(m)4-60	18.6	515	225	297	870

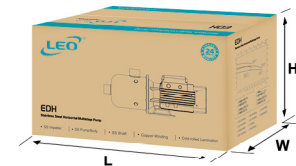

# EDH

## Stainless Steel Horizontal Multistage Pump



### Application

- It is applicable to household water supply, equipment support, pipeline pressurization, garden watering, vegetable greenhouse watering, fish farming and poultry raising, industrial and mining, water supply and drainage of enterprises and high-rise buildings, central air conditioner and centralized heating circulation system, etc.

### Pump

- AISI 304 shaft
- Max. liquid temperature: +85°C
- Altitude: up to 1000 m
- Max. suction: 8 m
- Max. inlet pressure: limited by max. operating pressure
- Max. operation pressure: 10 bar
- Liquid PH value: 4 - 10

### Motor

- IE2 motor (IE3 motor available on request)
- Motor with copper winding
- Built-in thermal protector for single phase motor
- Insulation class: F
- Protection class: IP55
- Max. ambient temperature: +40°C

### Identification Codes

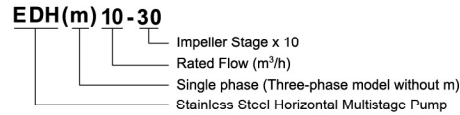

### Technical Data

Model	Power		Q (m <sup>3</sup> /h)	H (m)													
	kW	HP		Q (l/min)	6	7	8	9	10	11	12	13	14				
EDH(m)10-10	0.75	1.0	100	9.1	8.7	8.3	7.8	7.1	6.4	5.4	4.4	3.1					
EDH(m)10-20				17.9	17.1	16.3	15.3	13.9	12.4	10.7	8.4	6.2					
EDH(m)10-30	1.1	1.5	133	27.5	26.5	25.2	23.6	21.7	19.3	17	14	10					
EDH(m)10-40	1.5	2.0	150	38.7	37.2	35.0	33.0	31.6	28.7	24.0	19.7	15.0					
EDH(m)10-50	2.2	3.0	167	47.2	45.4	43.6	41	38.2	34.2	30	24.5	18					

### Dimension

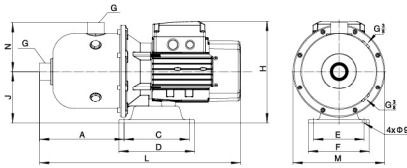

Model	L	A	C	D	E	F	G	H	J	M	N
EDH(m)10-10	568	278	138	160	108	130	G2	245	120	Φ233	140
EDH(m)10-20	568	278	138	160	108	130	G2	245	120	Φ233	140
EDH(m)10-30	568	278	138	160	108	130	G2	245	120	Φ233	140
EDH(m)10-40	626	287	138	160	108	130	G2	248	120	Φ233	140
EDH(m)10-50	626	287	138	160	108	130	G2	248	120	Φ233	140

### Hydraulic Performance Curves

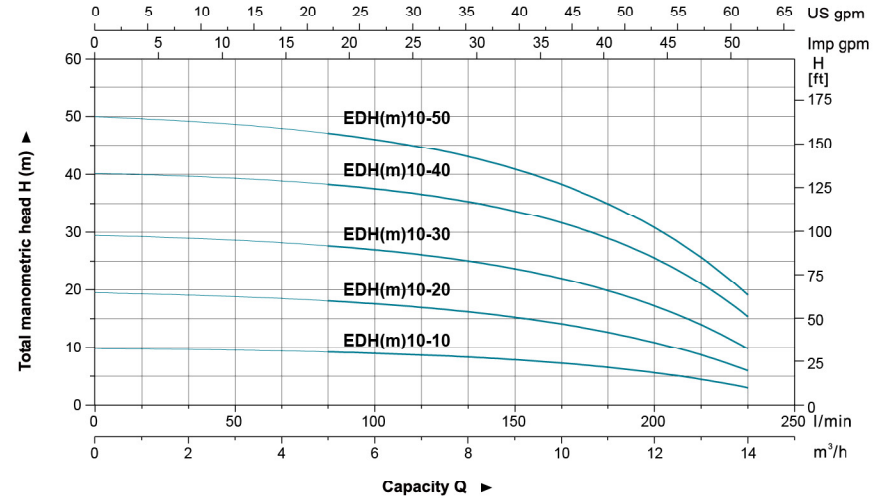

### Materials Table

No.	Part	Material
1	Pump body	AISI 304
2	Support	ZL102
3	Bottom plate	Cast iron
4	Stator	
5	Rotor	
6	Bearing	
7	Rear cover	ZL102
8	Fan	PP
9	Fan cover	08F
10	Bracket cover	AISI 304
11	Mechanical seal	SiC/Carbon
12	Positioning sleeve	AISI 304
13	Diffuser 3	AISI 304
14	Diffuser 2	AISI 304
15	Sleeve	AISI 304
16	Impeller	AISI 304
17	Diffuser 1	AISI 304
18	Pressure plate	AISI 304
19	Spacer bush	AISI 304

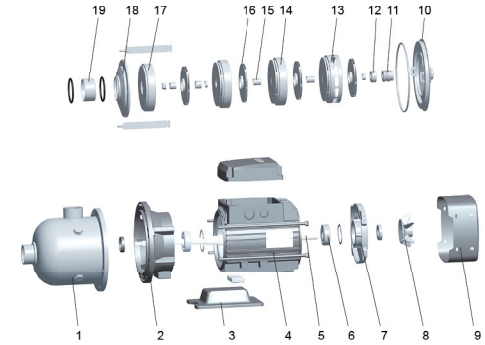

### Package Information

Model	GW (Kgs)	L (mm)	W (mm)	H (mm)	Quantity (PCS/20 TEU)
EDH(m)10-10	21.5	610	265	317	540
EDH(m)10-20	22	610	265	317	540
EDH(m)10-30	23	610	265	317	540
EDH(m)10-40	29	660	265	317	480
EDH(m)10-50	30.7	660	265	317	480

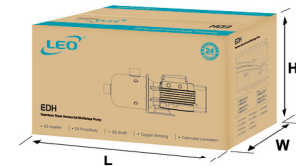

# EDH

## Stainless Steel Horizontal Multistage Pump

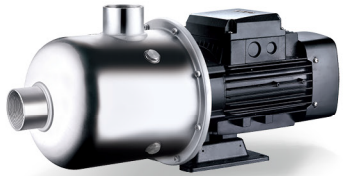

### Application

- It is applicable to household water supply, equipment support, pipeline pressurization, garden watering, vegetable greenhouse watering, fish farming and poultry raising, industrial and mining, water supply and drainage of enterprises and high-rise buildings, central air conditioner and centralized heating circulation system, etc.

### Pump

- AISI 304 shaft
- Max. liquid temperature: +85°C
- Altitude: up to 1000 m
- Max. suction: 8 m
- Max. inlet pressure: limited by max. operating pressure
- Max operation pressure: 10 bar
- Liquid PH value: 4 - 10

### Motor

- IE2 motor (IE3 motor available on request)
- Motor with copper winding
- Built-in thermal protector for single phase motor
- Insulation class: F
- Protection class: IP55
- Max. ambient temperature: +40°C

### Identification Codes

#### EDH(m) 15-20

- Impeller Stage x 10
- Rated Flow (m<sup>3</sup>/h)
- Single phase (Three-phase model without m)
- Stainless Steel Horizontal Multistage Pump

### Technical Data

Model	Power		Q (m <sup>3</sup> /h)	Q (l/min)									
	kW	HP		9	11	13	15	17	19	22	25	28	
EDH(m)15-10	1.1	1.5	H (m)	11.6	11	10.4	9.7	9.1	8.5	7.7	5.9	4.8	
EDH(m)15-20	2.2	3.0		25.4	24.5	23.4	22.2	21.1	19.7	17.4	15	12	
EDH15-30	3.0	4.0		38.4	37.2	35.8	34.1	32.3	30.2	26.6	22.8	18.8	

### Dimension

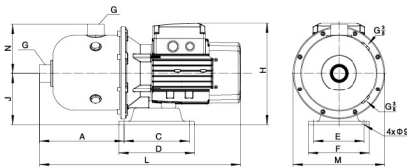

Model	L	A	C	D	E	F	G	H	J	M	N
EDH(m)15-10	568	278	138	160	108	130	G2	245	120	Φ233	140
EDH(m)15-20	626	287	138	160	108	130	G2	248	120	Φ233	140
EDH15-30	626	207	130	160	100	130	G2	240	120	Φ233	140

### Hydraulic Performance Curves

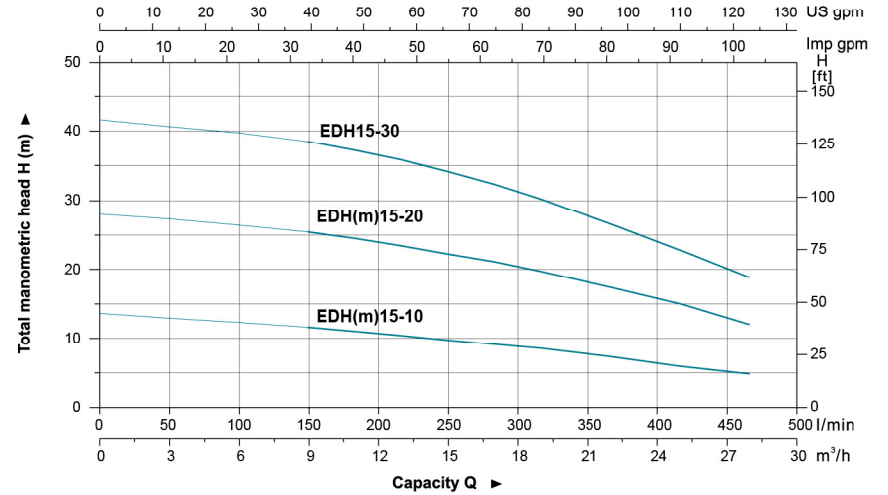

### Materials Table

No.	Part	Material
1	Pump body	AISI 304
2	Support	ZL102
3	Bottom plate	Cast iron
4	Stator	
5	Rotor	
6	Bearing	
7	Rear cover	ZL102
8	Fan	PP
9	Fan cover	08F
10	Bracket cover	AISI 304
11	Mechanical seal	SiC/Carbon
12	Positioning sleeve	AISI 304
13	Diffuser 3	AISI 304
14	Diffuser 2	AISI 304
15	Sleeve	AISI 304
16	Impeller	AISI 304
17	Diffuser 1	AISI 304
18	Pressure plate	AISI 304
19	Spacer bush	AISI 304

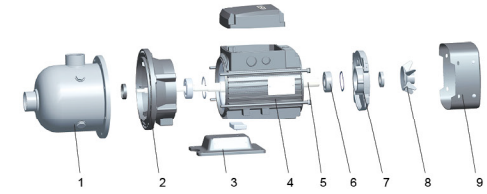
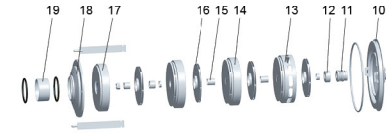

### Package Information

Model	GW (Kgs)	L (mm)	W (mm)	H (mm)	Quantity (PCS/20 TEU)
EDH(m)15-10	20.5	610	265	317	540
EDH(m)15-20	28.8	660	265	317	480
EDH15-30	33	660	265	317	480



# EDH

## Stainless Steel Horizontal Multistage Pump



### Application

- It is applicable to household water supply, equipment support, pipeline pressurization, garden watering, vegetable greenhouse watering, fish farming and poultry raising, industrial and mining, water supply and drainage of enterprises and high-rise buildings, central air conditioner and centralized heating circulation system, etc.

### Pump

- AISI 304 shaft
- Max. liquid temperature: +85°C
- Altitude: up to 1000 m
- Max. suction: 8 m
- Max. inlet pressure: limited by max. operating pressure
- Max. operation pressure: 10 bar
- Liquid PH value: 4 - 10

### Motor

- IE2 Motor (IE3 motor available on request. EDH20-30 not included)
- Motor with copper winding
- Built-in thermal protector for single phase motor
- Insulation class: F
- Protection class: IP55
- Max. ambient temperature: +40°C

### Identification Codes

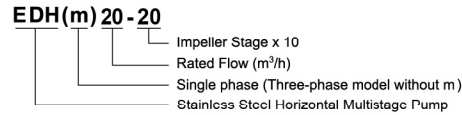

### Technical Data

Model	Power		Q (m <sup>3</sup> /h)	Q (l/min)									
	kW	HP		9	12	15	18	20	22	25	28	31	
EDH(m)20-10	1.1	1.5	H (m)	12.6	11.9	11.2	10.2	9.8	8.7	8	6.8	5.2	
EDH(m)20-20	2.2	3.0		26.5	25.7	24.5	23.1	22	20.8	18.5	15.9	13.2	
EDH20-30	4.0	5.5		41.2	40.3	38.9	36.9	35.3	33.2	30.1	26.3	22	

### Dimension

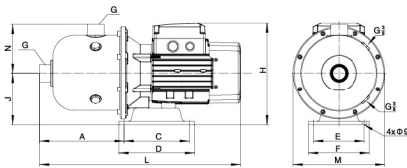

Model	L	A	C	D	E	F	G	H	J	M	N
EDH(m)20-10	568	278	138	160	108	130	G2	245	120	Φ233	140
EDH(m)20-20	626	287	138	160	108	130	G2	248	120	Φ233	140
EDH20-30	642	270	190	220	170	200	G2	240	120	Φ233	140

### Hydraulic Performance Curves

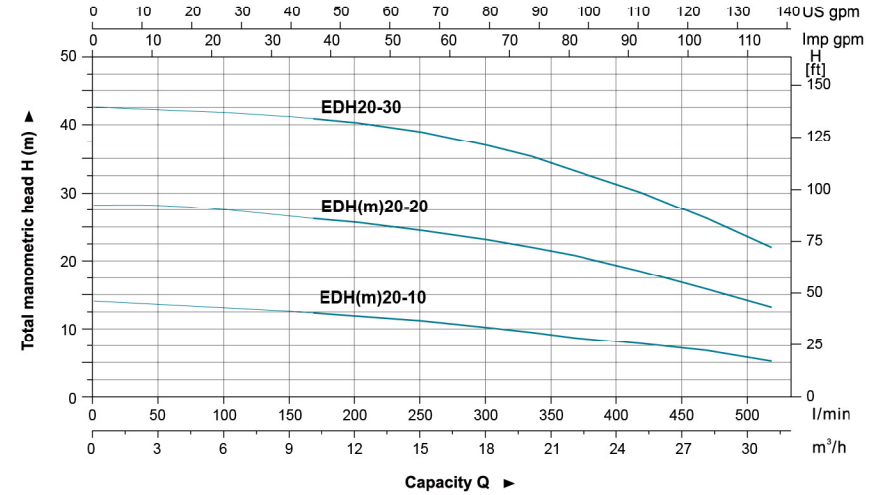

### Materials Table

No.	Part	Material
1	Pump body	AISI 304
2	Support	ZL102
3	Bottom plate	Cast iron
4	Stator	
5	Rotor	
6	Bearing	
7	Rear cover	ZL102
8	Fan	PP
9	Fan cover	08F
10	Bracket cover	AISI 304
11	Mechanical seal	SiC/Carbon
12	Positioning sleeve	AISI 304
13	Diffuser 3	AISI 304
14	Diffuser 2	AISI 304
15	Sleeve	AISI 304
16	Impeller	AISI 304
17	Diffuser 1	AISI 304
18	Pressure plate	AISI 304
19	Spacer bush	AISI 304

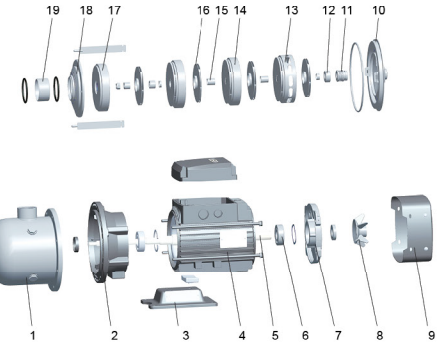

### Package Information

Model	GW (Kgs)	L (mm)	W (mm)	H (mm)	Quantity (PCS/20'TEU)
EDH(m)20-10	20.5	610	265	317	540
EDH(m)20-20	28.8	660	265	317	480
EDH20-30	37.5	675	265	317	480

