

ELECTRIC PUMP

EL1506

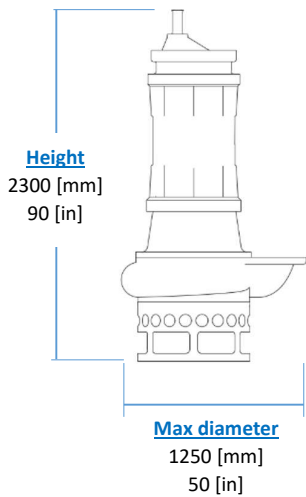
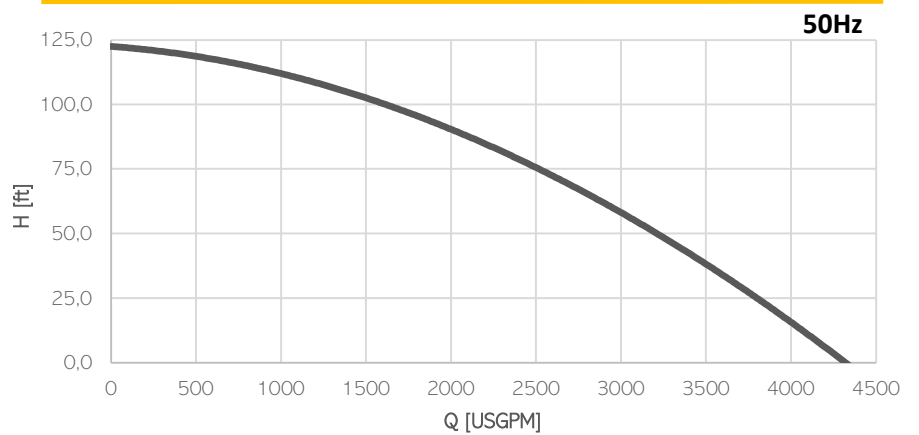
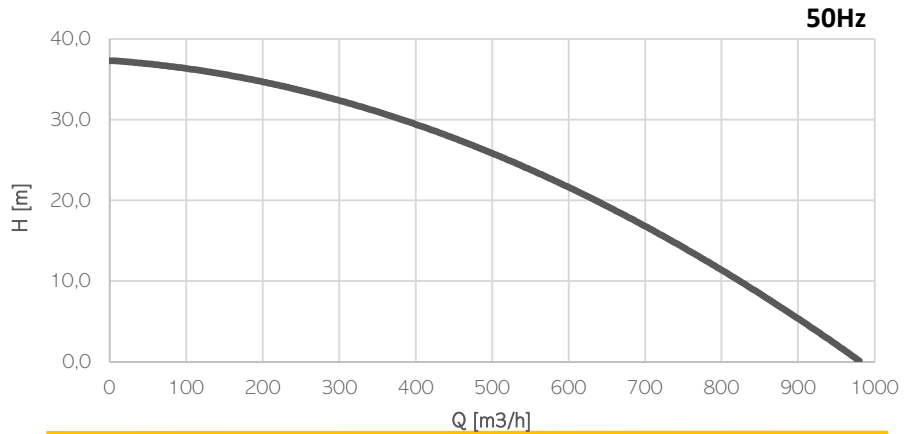

KG
Weight
 (without cable)
 2750 [kg]
 6060 [lb]

Electrical motor

Insulation class H

Cable

1 x H07RN-F 4G95 length 20m

Operating Conditions

- Max liquid temperature 35°C
- Min Submersion depth 1820 mm

Model	EL1506
Brake Power [kW HP]	110 147
Electric Power [kW HP]	120 161
Frequency [Hz]	50 -
Efficiency [%]	62% -
Number of Poles	6 -
RPM	980 -
Voltage [V]	400 -
Rated Current [A]	210 -
Solid handling [mm in]	60 2.4
Discharge [DN-PN]	200 PN10

Materials

Part	Standard
Casing	Cast Iron EN-GJS500
Body	Cast Iron EN-GIL250
Wear Parts	High chrome EN-GJN-HV600 (CH6)
Minimum hardness [HB]	550
Main shaft	High tensile 39NiCrMo3
PH Range	5-10

Seals and lubricants

Version	-	-	MS
Motor Side	-	-	MECHANICAL
Impeller Side	-	-	MECHANICAL
Oil type	-	-	ISO32