

# **NOVA SERIES DOSING PUMP USER MANUAL**

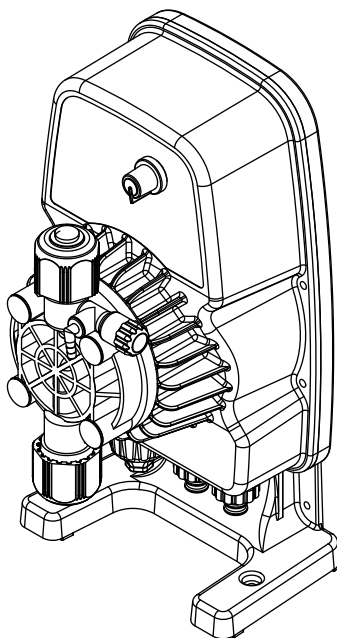

# Contents

<b>1 Contents</b>			9	Hydraulic Installation	16
1	Contents	1	9.1	Attaching Hose to Pump Head	16
1.1	List of Pictures	2	9.1.1	Priming	17
2	Introduction	3	9.2	Suction Line Assembly	18
2.1	Explanation of Safety Warnings	3	9.3	Stroke Line Assembly	19
2.2	User Competence	4	9.4	Head Set Assembly	20
3	Safety and Responsibility	5	9.4.1	40" Head Set Assembly	20
3.1	General Safety Warnings	5	9.4.2	70" Head Set Assembly	20
3.2	Hazards arising from non-compliance with safety instructions	6	10	Electrical Installation	21
3.3	Safe operation	6	10.1	Principles	21
3.4	Personal protective equipment	6	10.1.1	Pump Connection Diagram	21
3.5	Personnel competence	6	10.1.2	AC Input Connection	21
4	Appropriate and Desired Use	7	10.1.3	DC Input Connection	21
4.1	Notes about product warranty	7	11	Operation	22
4.2	Purpose of production	7	11.1	Device Functions	22
4.3	Device revision	7	11.1.1	Buttons	22
4.4	Principles	7	11.1.2	Indicators	22
4.5	Prohibited dosage media	7	11.2	Analogue Model Pump Details	23
4.6	Foreseeable wrong use	7	11.2.1	Function Settings	23
4.6.1	Wrong assembly	8	12	Maintenance	24
4.6.2	Wrong installation	8	12.1	To clean	24
4.6.3	Wrong electrical wiring	8	13	Troubleshoot	25
4.6.4	Erroneous commissioning	8	13.1	Mechanical Malfunctions	25
4.6.5	Erroneous operation	8	13.2	Electrical Malfunctions	25
4.6.6	Wrong maintenance	8	13.2.1	Replacing the Fuse	25
5	Product Description	9	14	Chemical Resistance List	26
5.1	Product Data	9	15	Pump Flow Pressure Graphics	27
5.2	Scope of delivery	9	16	Warranty / Standards	28
6	Technical Data	10	16.1	Warranty	28
6.1	Model List	10	16.2	Standards	28
6.2	Additional Electrical Data	10			
7	Dimensions	11			
7.1	Pump size for 40" head	11			
7.2	Pump size for 70" head	11			
8	Installation	11			
8.1	Pump Assembly Hole Dimensions	12			
8.1.1	Pump Body Assembly Hole Dimensions	12			
8.1.2	Pump Assembly Stand Hole Dimensions	12			
8.2	Pump Assembly Position	13			
8.3	Assembly to Wall or Plastic Panel	14			
8.4	General Assembly of the Device	15			

---

## 1.1 List of Pictures

Picture 1 Nova Series Pump Sizes	11
Picture 2 Pump Body Assembly Hole Dimensions	12
Picture 3 Pump Stand Assembly Hole Dimensions	12
Picture 4 Pump Correct Assembly Position	13
Picture 5 Pump Wrong Assembly Position	13
Picture 6 Wall Assembly	14
Picture 7 Plastic Panel Assembly	14
Picture 8 General Assembly	15
Picture 9 Attaching Hose to 40" Head	16
Picture 10 Attaching Hose to 70" Head	16
Picture 11 Priming	17
Picture 12 Suction Line Assembly Diagram	18
Picture 13 Stroke Line Assembly Diagram	19
Picture 14 40" Head Set Assembly Diagram	20
Picture 15 70" Head Set Assembly Diagram	20
Picture 16 Pump Power Input	21
Picture 17 Pump Power Connection	21
Picture 18 AC Input Connection Diagram	21
Picture 19 Cable Color and DC Input Connection	21
Picture 20 Screen Functions	22
Picture 21 Replacing the fuse	25

# Introduction

## 2 Introduction

Please read following information carefully and completely. This information shall ensure that you benefit from operating instructions at optimum level.

These instructions define the functions of technical data.

### 2.1 Explanation of Safety Warnings

These operating instructions give information about the technical data and functions of the product. And provide detailed safety information.

Safety warnings and notes are categorized as below. Pictographs are used here as adapted for different circumstances. These pictographs are only for example.



#### **DANGER!**

##### **Type and source of danger**

**Result:** Death or severe injury.

Measures to be taken to prevent such danger.

##### **Danger!**

Defines the danger that creates the threat directly. Causes death or severe injury unless prevented.



#### **WARNING!**

##### **Type and source of danger**

**Possible Result:** Death or grave injury.

Measures to be taken to prevent such danger.

##### **Warning!**

Defines a possible dangerous situation. Causes death or grave injury unless prevented.



#### **CAUTION!**

##### **Type and source of danger**

Possible Result: Light or insignificant injuries. Material damage.

Measures to be taken to prevent such danger.

##### **Caution!**

Defines a possible dangerous situation. Causes light or insignificant injury unless prevented. Can also be used for material damage warning.



#### **NOTE!**

##### **Type and source of danger**

Causing damage to the product or individuals.

Measures to be taken to prevent such danger.

##### **Note!**

Defines a possible damaging action. Causes damage to the product or individuals unless prevented.



#### **INFORMATION!**

Operational tips and additional information

Source of information. Additional measures.

##### **Information!**

Defines operational tips and other useful information. Not given for a dangerous or harmful situation.

## 2.2 User Competence



### WARNING!

**Danger of injury in case of personnel incompetence!**

**Operator of device/facility is responsible for complying with competencies.**

Incompetent personnel working with the device or keeping the device in danger zone might cause severe injuries or material losses.

- All operations should be handled by competent personnel
- Keep away incompetent personnel from danger zones

Training	Description
Informed Person	Defines a person that has been informed about possible hazards in case of unruly behaviors contrary to duties assigned, and informed about relevant situations and informed about necessary protection equipment and measures.
Trained User	Defines a person that meets the standards of an informed person and plus trained by the manufacturer or another authorized sales partner
Trained Expert	Defines a person that can recognize possible hazards and evaluate the duties assigned thanks to his/her knowledge of rules in addition to the training, information and experience in that field. The activities based on years of experience in that field can be taken into consideration while assessing someone as an expert.
Electricity Expert	Defines a person that can work in electrical facilities, and recognize and prevent possible dangers thanks to his/her knowledge of regulations and standards in place in addition to the training, information and experience. Electricity experts should have received training on the field of work and have knowledge on important standards and regulations. Electricity expert should fulfill the provisions of legal regulations for preventing accidents.
Customer Services	The service technicians that are trained and authorized for operations in the facility by the manufacturer are described as customer services.

## Safety and Responsibility

### 3 Safety and Responsibility

#### 3.1 General Safety Warnings

Following warnings are given for assisting you to eliminate possible dangers that might arise while using the product. Risk prevention measures are always valid independent of any special action. Safety instructions that give warning against certain activities or situations are given in relevant sub-sections.

	<b>DANGER</b>
<p>Life-threatening danger due to electric shock Falsely wired, exposed or damaged cables might injure you. Replace damaged cables immediately. Do not use extension cables. Do not bury cables. Fix cables to prevent damage to other equipment.</p>	

	<b>DANGER</b>
<p>Do not use the product in explosive environments.</p>	

	<b>WARNING</b>
<p><b>Caustic burns due to dosage material or other types of burns!</b> Dosage starts after connection to the mains power. Connect dosage lines before connecting to mains power. Make sure that all screws are tightened and sealed properly.</p>	

	<b>WARNING</b>
<p>While working on dosage head, valves and connections, you might get in touch with dosage liquid. Use sufficient personal protective equipment. Rinse the product with a liquid that doesn't bear any risk (e.g. water). Make sure that the liquid is in line with the dosage material. Do not look at the exposed ends of attached pipe lines and valves without protective goggles.</p>	

	<b>WARNING</b>
<p>Product materials and system hydraulic parts should be compliant to dosage liquid. Make sure that the materials are suitable for the dosage material.</p>	

	<b>CAUTION</b>
<p>Increased accident risk due to lack of qualification on personnel side! Dosage pumps and accessories can only be mounted, operated and maintained by staff with sufficient qualifications. Incompetence will increase risk of accident. Make sure that all actions are taken by personnel with sufficient and appropriate qualifications. Prevent access to system by unauthorized persons.</p>	

	<b>CAUTION</b>
<p>Personal injury and material damage hazard! Changing the dosage liquid might cause unforeseeable reactions. In order to prevent chemical reactions, clean dosage pumps and hoses thoroughly.</p>	

### 3.2 Hazards arising from non-compliance with safety instructions

Non-compliance with safety instructions will bring risks not only for the staff but also for environment and the unit.

Here are some specific consequences:

Failure of vital functions in product and system,  
Failure of necessary maintenance and repair methods,  
Danger for individuals due to dangerous dosage material,  
Environmental hazard due to leaking materials.

### 3.3 Safe operation

There are more safety rules in addition to the safety instructions stated in this operating manual and they should be followed:

Accident prevention regulations safety and operating provisions

Safety measures for using dangerous items

Environmental protection provisions,

Applicable standards and legislation.

### 3.4 Personal protective equipment

You might be exposed to dosage liquid. You should use relevant protective equipment depending on the type of work and degree of risk.

As minimum, following protective equipment is provided:



Protective  
Clothing



Protective  
Gloves



Protective  
Goggles

The operator should use protective equipment during these tasks:

Assigning,  
When device is working,  
Demounting, maintenance works, disposal.

### 3.5 Personnel competence

Any staff member working on the device should have specific knowledge and skills.

Anyone working on the device should meet following conditions:

- Participation in all training courses,
- Personal fitness to the specific task,
- Personal competence for the specific task,
- Training for the use of device,
- Safety equipment data and mode of operation
- This Operating Manual and especially the safety instructions relevant to this work with sub-sections,
- Knowledge on basic arrangements relevant to health, safety and accident-prevention.

All persons should have following qualifications as minimum:

-Receive training as expert to work on the product independently,

-Receive sufficient training to work on the product under the guidance and surveillance of a trained expert.

This user's manual differentiates between user groups

(See 2.2. User's Competence Page 4)

## Appropriate and Desired Use

### 4 Appropriate and Desired Use

#### 4.1 Notes about product warranty

Undefined use of the product in any way might risk the function or desired protection of the product. This shall invalidate warranty claims!

Please remember that responsibility lies with the user in following cases:

Use of the dosage pump against the user's manual and in an inconsistent way with the section titled "appropriate and desired use" especially with regards to safety.

When persons use incompetent products to perform relevant activities (See 2.2. User's Competence Page 4).

When unauthorized changes are made on the device by the user,

When user chooses a different dosage media than the one stated in the order.

Users should not prefer dosage liquid that is in a changed concentration, density, temperature, etc. against the manufacturer's conditions.

#### 4.2 Purpose of production

NOVA analogue dosage pump has been designed for the following purpose:  
Handling and dosage of liquids.

#### 4.3 Device revision

This user's manual applies to following devices.

Devices	Version
Nova Analog Dosage pump	V0.R2

#### 4.4 Principles

- The manufacturer has checked and operated the device under specific conditions before delivery (in a specific density and temperature with a specific dosage material, under specific pipe dimensions, etc.).
- Since such conditions may vary on site under different usages, the capacity of the product should be measured during installation by the operator company.
- Information on usage and environment (see 6. Technical Data page 10).
- Product materials and system hydraulic parts should be compliant to dosage material. Please remember that resistance of components shall vary depending on dosage material temperature and operating pressure.
- Product is not designed for outdoors unless appropriate protective measures are taken.
- Avoid liquid and dust leakage into product and also direct sunlight exposure.
- Do not operate the product in a potentially explosive environment unless there is EC Certificate of Conformity for potentially explosive atmospheres.

#### 4.5 Prohibited dosage media

Product should not be used for following materials and ingredients:

- Gaseous substances,
- Flammable materials,
- Radioactive substances,
- Solid materials.

#### 4.6 Foreseeable wrong use

You can find below information about unaccepted product practices or relevant equipment practices. This section has been designed to detect and prevent possible wrong uses beforehand. Foreseeable wrong use will affect product life:



### 4.6.1 Wrong assembly

Wrong or loose screwing.

### 4.6.2 Wrong installation

Wrong installation of suction and stroke lines.

Wrong connection of pipes due to wrong material or improper connections.

Damage in pipe lines due to twisting or excessive tightening.

Use of damaged parts or exceeding the permitted pressure on suction and discharge sides.

### 4.6.3 Wrong electrical wiring

Unsafe mains or mains voltage that do not comply with standards.

Wrong connection cables for mains voltage.

Installation where it is not possible to cut off power supply immediately or easily.

### 4.6.4 Erroneous commissioning

Commissioning with damaged facility

Shut-off valve closed to circuit

Closed suction or pressure line, (e.g. due to clogging)

Staff not experienced with the device

( See 2.2. User's Competence Page 4).

Insufficient protective equipment

### 4.6.5 Erroneous operation

Auxiliary equipment not working properly or fall apart

Unauthorized replacement of dosage pump

Negligence of operational faults

Elimination of operational faults by unauthorized staff without necessary competencies

( See 2.2. User's Competence Page 4).

Turning off the external fuse

### 4.6.6 Wrong maintenance

Performing maintenance on a running dosage pump

Performance of activities not described in the user's manual or insufficient or irregular control for correct operation

Inability to replace damaged pieces or cables due to insufficient insulation

Absence of any precaution against accidental commissioning during maintenance

Use of cleaning substances that might cause reaction with dosage media

Use of inappropriate cleaning equipment with wrong spare parts or lubricants

Installing spare parts without following the instructions in user's manual

Confusing sensor lines while reconnecting all lines

Failure to renew gaskets (damage in all gaskets or failure to remove them)

Negligence of safety data forms and insufficient protective equipment

## Product Description

---

### 5 Product Description

---

#### 5.1 Product Data

Dosage pumps are precision dosage devices designed for dosage release of acid, chlorine, liquid fertilizer, etc chemicals (pool, potable water, agricultural irrigation, etc.)

Suitable for the dosage of abrasive and toxic liquid chemicals

Wall and ground assembly option

#### 5.2 Scope of delivery

Please compare the delivery note with the scope of delivery. Following items are covered by delivery scope:

Dosage pump

Suction Line Set

Stroke Line Set

Hose Set (Suction Line, Stroke Line and for priming)

Pump Assembly Stand

User's Manual

**6 Technical Data**

**6.1 Model List**

DP NOVA A	Max /Lt	Max /P	Stroke /min	MI /Stroke	Supply Voltage	Watt	Weight	Body	Max Ambient Temp.	Max Chemical Temp.	Diaphragm diameter
	Lt/h	Bar	Stroke	ml	Volt	W	kg	IP	°C	°C	Diaphragm Ø
12L/4B	12	4	150	1.33	12-28VDC	38	4.1	65	50	45	65.5
4L/7B	4	7	150	0.44		16					43.5
3,5L/20B	3.5	20	150	0.39	95-260VAC 50-60 Hz	15					43.5
10L/10B	10	10	300	0.56		25					43.5
25L/5B	25	5	300	1.39		27					65.5

**6.2 Additional Electrical Data**

Alarm Relay	250VAC 5A / 30VDC 5A	
Fuse Value	In AC Models	In DC Models
	3A Fast Acting 5x20mm Cartridge Fuse	10A Fast Acting 5x20mm Cartridge Fuse

## Dimensions

### 7 Dimensions

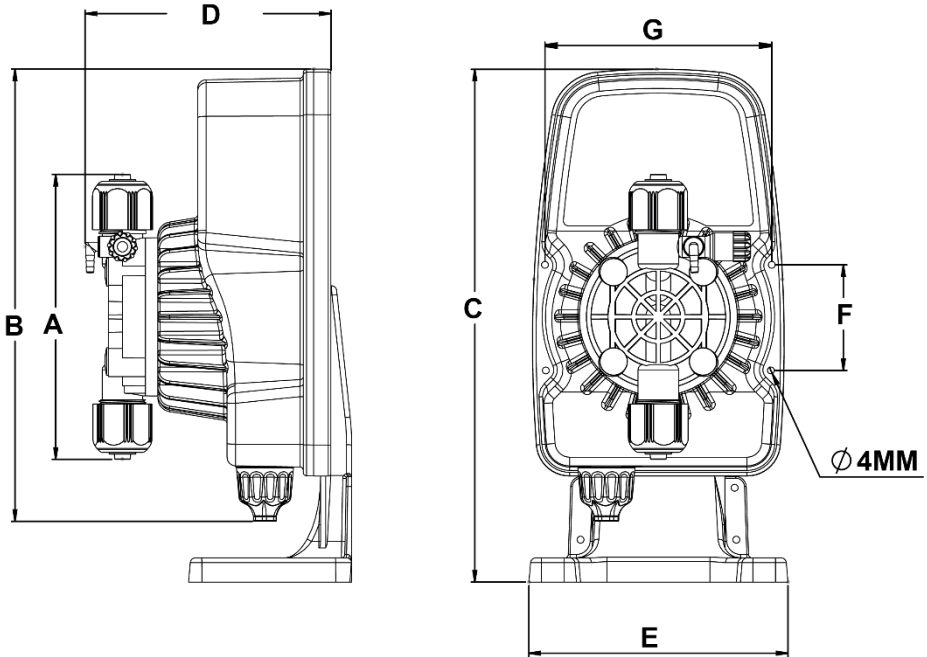

Picture 1 Nova Series Pump Sizes

#### 7.1 Pump size for 40" head

<b>A</b>	: 136 mm	<b>E</b>	: 146 mm
<b>B</b>	: 261 mm	<b>F</b>	: 61 mm
<b>C</b>	: 300 mm	<b>G</b>	: 131 mm
<b>D</b>	: 141 mm		

#### 7.2 Pump size for 70" head

<b>A</b>	: 170 mm	<b>E</b>	: 146 mm
<b>B</b>	: 261 mm	<b>F</b>	: 61 mm
<b>C</b>	: 300 mm	<b>G</b>	: 131 mm
<b>D</b>	: 141 mm		

\* Head set sizes may vary depending on pump capacity data. Capacity data: ( See 6.1. Capacity Info page 10).

## 8 Installation

### 8.1 Pump Assembly Hole Dimensions

Dosage pump assembly holes are shown in following pictures.

Mark the surface on which the pump is to be installed in accordance with the template before starting assembly.

Make sure that the surface for pump installation is dry and clean.

#### 8.1.1 Pump Body Assembly Hole Dimensions

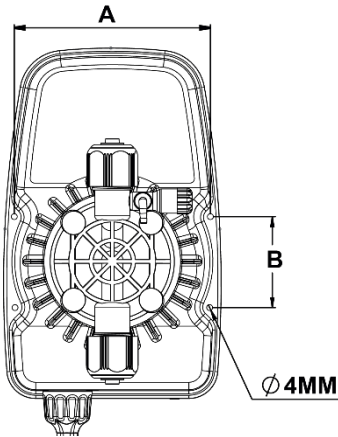

Picture2 Pump Body Assembly Hole Dimensions

Dimensions/mm

**A** 131 mm      **B** 61 mm

#### 8.1.2 Pump Assembly Stand Hole Dimensions

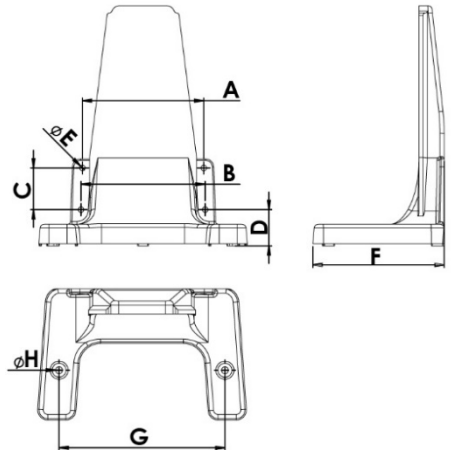

Picture3 Pump Stand Assembly Hole Dimensions

Dimensions/mm

<b>A</b>	87 mm	<b>E</b>	4 mm
<b>B</b>	89 mm	<b>F</b>	94 mm
<b>C</b>	30 mm	<b>G</b>	119 mm
<b>D</b>	26 mm	<b>H</b>	5 mm

# Installation

## 8.2 Pump Assembly Position

	<b>NOTE</b>
Place the dosage pump vertically $\pm 45^\circ$ . Fix the pump to a wall or any other vertical surface through two holes.	

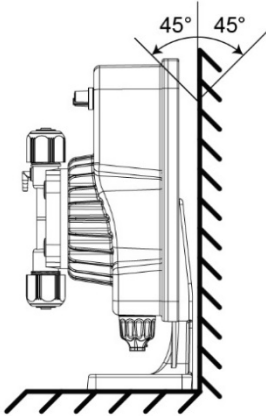

Picture 4 Pump Correct Assembly Position



Correct assembly

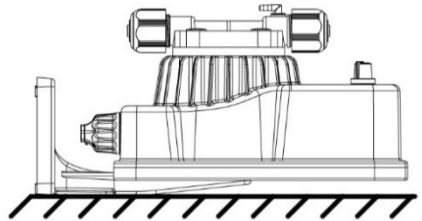

Picture 5 Pump Wrong Assembly Position



Wrong Assembly

### 8.3 Assembly to Wall or Plastic Panel

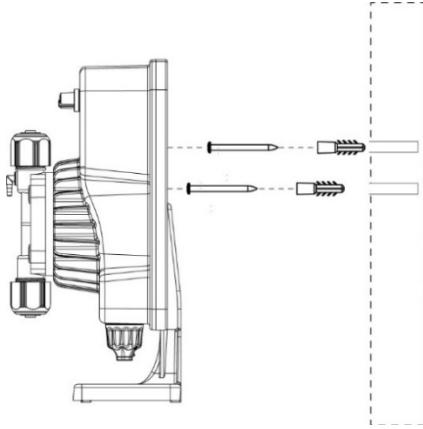

Picture 6 Wall Assembly

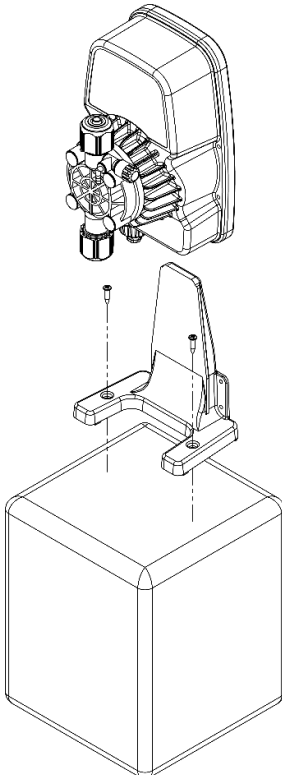

Picture 7 Plastic Panel Assembly

Use the hole template in accordance with your pump's model to fix it to a wall

For Hole Sizes, See Page 15.

Mark the surface that you would like to fix the pump based on given sizes.

Drill maximum 7mm hole on the surface to drive in 8mm anchors that you will find among the accessories.

After driving in the anchors, place the pump in such a way that holes overlap.

Fix with screws.

For Stand Assembly:

To assemble the device with pump assembly stand, fix the SCREW M4,2X19 YSB CHROMIUM PLATE as shown here.

For Pump Assembly Stand hole sizes

See 8.1.2. Pump Assembly Stand hole sizes page 12

## Installation

### 8.4 General Assembly of the Device

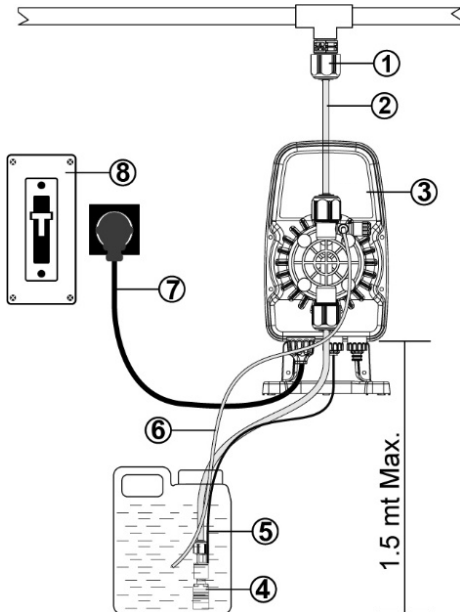

Picture 8 General Assembly

- 1- Pumping line
- 2- Stroke line hose
- 3- Dosage pump
- 4- Suction line
- 5- Liquid level sensor
- 6- Priming release hose
- 7- Power cable
- 8- Electricity safety panel

General assembly of the device should be performed as shown above.

Distance between suction line and pump, placed inside the liquid tank, should be maximum 1,5 meters.

Assembly should be completed before electrical connection has been made.

Electrical connection should be in such a distance not to be affected by liquid or chemicals.

Device should be placed in a distance that provides ease of use and reading for user's access.

To make your device long lasting and properly operating, assembly site should not be wet or humid.



## 9 Hydraulic Installation

### 9.1 Attaching Hose to Pump Head

Attaching Hose to  
40" Head

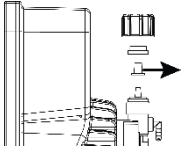

Picture9 Attaching Hose to  
40" Head

Attaching Hose to  
70" Head

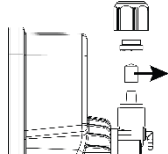

Picture10 Attaching Hose to  
to 70" Head

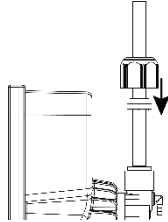
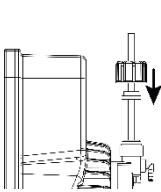

Remove Union covers.

Remove safety plugs that have been added  
at production stage.

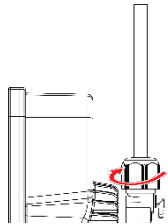
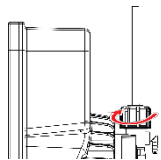

After passing pipes through union covers,  
place them on conical tips on unions and tighten  
the union covers and lock.

## Hydraulic Installation

### 9.1.1 Priming

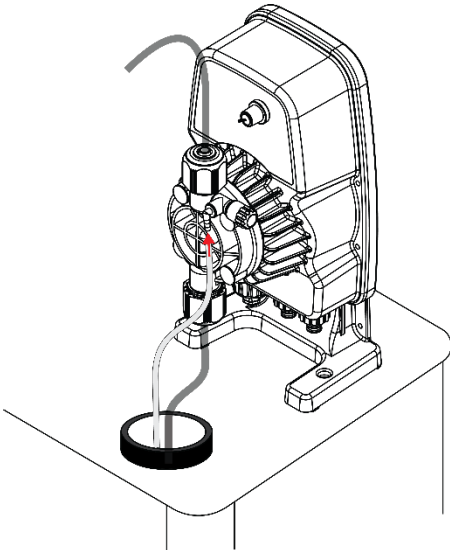

Picture11 Priming

Before commissioning the pump, air in the pump head should be bled.

For this, attach the PVC hose that you can find among the accessories to the air bleed union on dosage pump, whose assembly and wiring should be completed beforehand, and then send the output to chemical tank

Loosen the air bleed union.

Start the pump.

Check whether chemical is resupplied to the tank from the hose connected to air bleed union.

Priming is over.

Close tight the priming union.

This can not be manually done in models equipped with automatic priming feature.

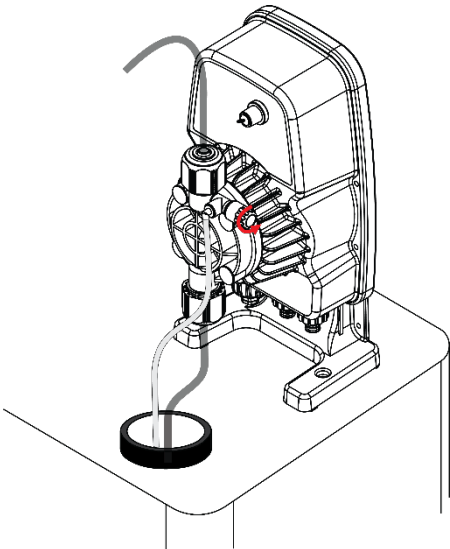

9.2 Suction Line Assembly

	<b>NOTE</b>
<p>Suction line should always be attached to lower part of the pump and dipped into chemical tank</p> <p>All parts of the suction line should be attached in the order and direction as shown below.</p> <p>Your pump will not absorb if order or direction of parts is changed.</p>	

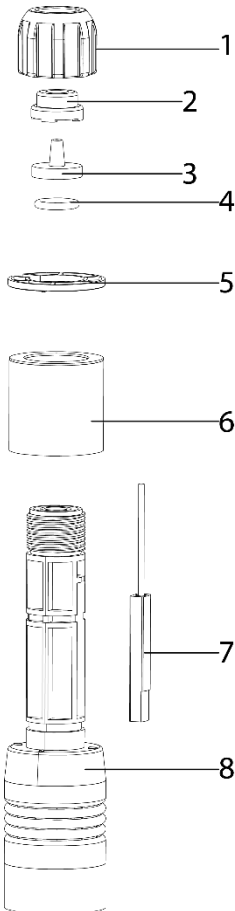

No	Description	Unit
1	Union Cover 2 3/4	1
2	Hose End 9x12	1
3	Hose Press 9x12	1
4	Oring 11x2 Viton	1
5	Plastic Snap Ring	1
6	Sensor Body	1
7	Sensor	1
8	Suction Body	1

Picture12 Suction Line Assembly Diagram

# Hydraulic Installation

## 9.3 Stroke Line Assembly

	<b>NOTE</b>
<p>Stroke line should always be attached between pump's outlet union and pressurized line.</p> <p>All parts of the stroke line should be attached in the order and direction as shown below.</p> <p>Your pump will not pump if order or direction of parts is changed.</p>	

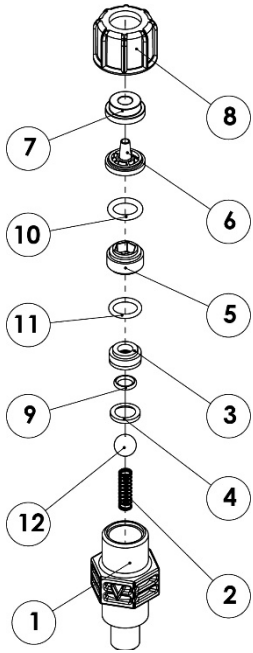

Picture13 Stroke Line Assembly Diagram

No	Description	Unit
1	STROKE BODY 1 PP	1
2	ARCH 6X28MM 5MMX12S	1
3	BALL HOUSING BODY PVDF	1
4	BALL HOUSING SHIM PVDF	1
5	BALL HOUSING COVER PP	1
6	HOSE TIP 4X6 PP	1
7	HOSE PRESS 4X6 PP	1
8	UNION COVER 2 PP	1
9	ORING 6,75x1,78 VITON	1
10	ORING 11x2,5 VITON	1
11	ORING 11x2 VITON	1
12	BALL 10MM CERAMIC	1

## 9.4 Head Set Assembly

	<b>NOTE</b>
<p>All parts of the head set should be attached in the order and direction as shown below.</p> <p>Your pump will not release chemical if order or direction of parts is changed.</p>	

### 9.4.1 40" Head Set Assembly

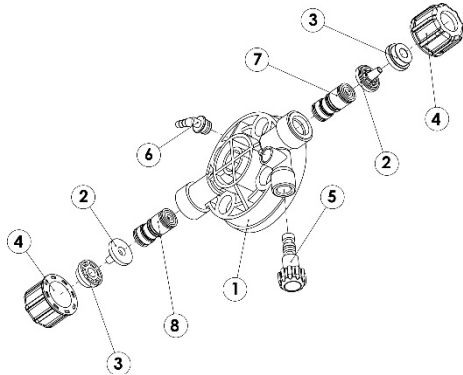

Picture14 40" Head Set Assembly Diagram

No	Description	Unit
1	PUMP HEAD 40 PVDF	1
2	HOSE TIP 4X6 PVDF	2
3	HOSE PRESS 4X6 PVDF	2
4	UNION COVER 2 PVDF	2
5	UNION PRIMING 2 PVDF	1
6	PRIMING TIP PVDF	1
7	CARTRIDGE SET STROKE	1
8	CARTRIDGE SET SUCTION	1

### 9.4.2 70" Head Set Assembly

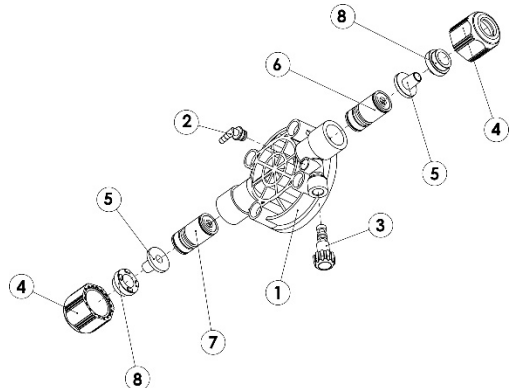

Picture15 70" Head Set Assembly Diagram

No	Description	Unit
1	PUMP HEAD 70 PVDF	1
2	PRIMING TIP PVDF	1
3	UNION PRIMING 2 PVDF	1
4	UNION COVER 3/4 16MM PVDF	2
5	HOSE TIP 9X12 PVDF	2
6	CARTRIDGE SET STROKE	1
7	CARTRIDGE SET SUCTION	1
8	HOSE PRESS 9X12 PVDF	2

# Electrical Installation

## 10 Electrical Installation

### 10.1 Principles

There is a power supply unit in dosage pump with a wide interval of 95 - 265 V AC 50/60 Hz.

Electrical wiring is in compliance with local regulations.

Dosage pump should be plugged into a grounded power outlet.

Dosage pump should be electrically locked to avoid dosage errors at the end of the operation.

Dosage pump should not be started by turning on or off the mains voltage.

pulse cables should not be installed in parallel to high voltage current lines or mains cables. You should direct feeding and pulse lines to different channels. You need 90° angle in line passage.

AC and DC connection input is given in the next diagram.

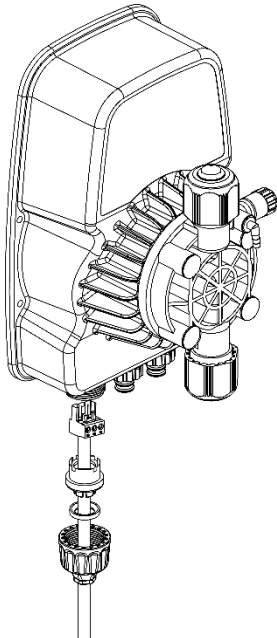

Picture16 Pump Power Input

### 10.1.1 Pump Connection Diagram

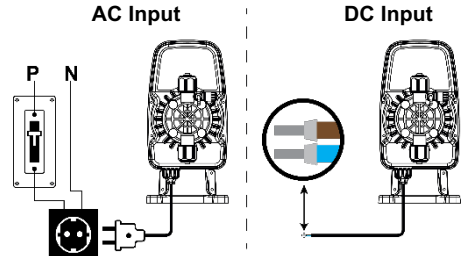

Picture17 Pump Power Connection

### 10.1.2 AC Input Connection

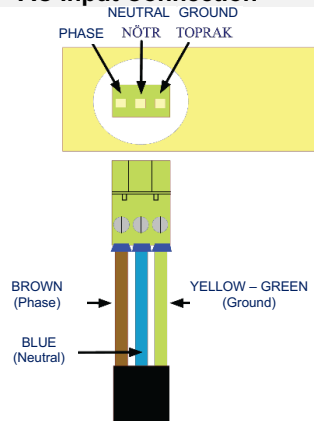

Picture18 AC Input Connection Diagram

### 10.1.3 DC Input Connection

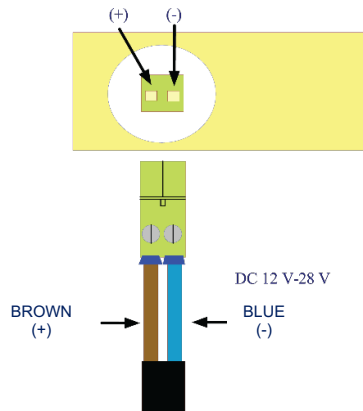

Picture19 Cable Color and DC Input Connection

## 11 Operation

### 11.1 Device Functions

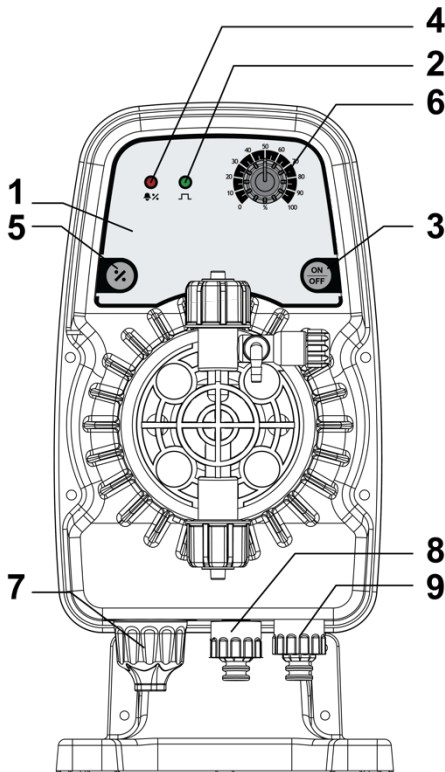

Picture 20 Screen Functions

- 1- Panel label
- 2- Pulse LED
- 3- On off button
- 4- 10% mode and Alarm indicator LED
- 5- 10% mode on off button
- 6- Capacity control pot
- 7- Electrical connection union
- 8- Liquid Level Sensor Input 1
- 9- Liquid Level Sensor Input 2

### 11.1.1 Buttons

Icon	Description	Duty
	On-Off	Used for turning on and off the device.
	10% mode on off button	When 10% button is pressed, pump will start operating in its 10% capacity easily.

### 11.1.2 Indicators

Indicator	Description	Color
10% mode and Alarm indicator LED	LED no. 4 will light when pump is on 10% capacity.	Red
Pulse LED	LED will turn off if pump is striking.	Green

Your dosage pump operates with a Teflon (PTFE) diaphragm connected to an electromagnet driven with a direct current. When electromagnet pulls the piston, pressure is generated on pump head and released from dosage liquid output valve in a pressurized manner.

- Once electricity pulse is interrupted, a spring brings back the piston and liquid enters through input valve.
- Easy to use and no need for pump oiling. Consequently, it's maintenance-free.
- Materials in pump body are specially manufactured to protect against toxic and acidic substances.
- Pumps have been manufactured in various capacities to operate under max 5 Bar pressure between 0 and 25 lt/hour.
- Pump capacities are easily adjustable through capacity control pots on them in analogue models.

## Operation

---

### 11.2 Analogue Model Pump Details

You can adjust pump capacities of analogue models using the potentiometers on them. You can also mount liquid level sensor to level sensor input to stop operation of the pump when the liquid is consumed up.

#### 11.2.1 Function Settings

When 10% button no. 5 is pressed, pump will start operating in its 10% capacity easily. LED no. 4 will light when pump is on 10% capacity.

Liquid level sensor and Flow Sensor operation mode setting parameter can be selected as normally open or normally closed. To adjust sensor operation type, press and hold 10% button no. 5 until level LED blinks fast. Sensor operation mode will be open when level LED is on, and closed when it is off. Press 10% button no. 5 for switching between open and closed mode. Press On-Off button to confirm and save and exit from setting parameter, pump will return to normal operation mode.



---

## 12 Maintenance

---

Before deactivating the device at the end of the season;

Dismantle stroke line pipe from pumping line.

Remove the suction pipe from liquid tank with the drain and place into clean water.

Operate the pump for 5-10 minutes.

If the cleaning has not been made before deactivating the device at the end of season while using sodium hypochlorite, there might be a solid calcium layer on surfaces of the pump that contacts the chemical.

### 12.1 To clean

Dismantle stroke line pipe from pumping line.

Remove the suction pipe from liquid tank with the drain and place into clean water.

Operate the pump for 5-10 minutes.

Turn off the pump and dip the filter into hydrochloric acid and wait until acid cleans it.

Restart the pump and operate it for 5 minutes while keeping the suction filter and pumping union in the same tank.

Repeat the process with water.

Reconnect the pump



#### NOTE

Check the liquid level in chemical tank periodically so that you are not running the pump without dosage liquid.

Check pump operation with at least 5 hours intervals.

Hydraulic parts should be cleaned periodically however it depends on application type how frequently.

## Troubleshoot

### 13 Troubleshoot

#### 13.1 Mechanical Malfunctions

If the system is fully silent, probably there is an electrical or electronic failure rather than a mechanical one.

If there is a loss in dosage liquid in fixed interval, then the union covers might be loose or pumping line pipe might be cracked or there might be cracks in diaphragm (although quite rare) or 4 screws holding the pump head might be loose.

If there is air formation when pump is not in use, then check all check valves in the system and replace if necessary.

#### 13.2 Electrical Malfunctions

If one of the LEDs is not on or screen backlit is not working:

Check power connection.

Make sure that only authorized staff or service intervenes in all malfunctions in the power cable.



Power values should match the pump model.

See 6.2. Additional Electrical Data Page 10

Check pump fuse. If it is broken, replace with appropriate fuse. If the new fuse is also blowing, contact the pump dealer.

	<b>NOTE</b>
If the problem is none of those or if there is a different problem, contact the pump dealer	

#### 13.2.1 Replacing the Fuse

	<b>WARNING</b>
Your product warranty will become void if fuse is not replaced by the technical service.	
	<b>WARNING</b>
Disconnect the power before any service action on the device.	
Use appropriate cartridge fuse in dosage pumps. See 6.2. Additional Electrical Data Page 10	

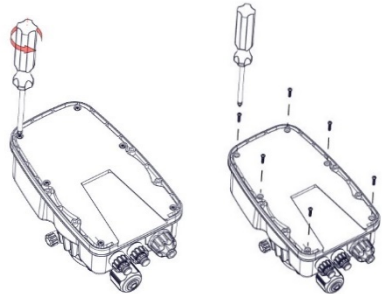

Remove the screws on the back cover with appropriate screwdriver to replace the pump fuse.

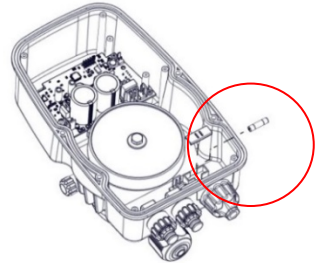

Picture 21 Replacing the fuse

Replace the cartridge fuse on the electronic card with the new one.

Make sure that electronic card is not damaged. Your pump will not operate if electronic card is damaged. Failures due to user's fault on the electronic card are not covered by the guarantee.

Then close the pump back cover.

**14 Chemical Resistance List**

Chemical	Formula	Glass	PVDF	PP	PVC	SS316	PMMA	Hastelloy	PTFE	FPM	EPDM	NBR	PE	Neoprene	Silicone
Acetic Acid, Max 75%	<b>CH<sub>3</sub>COOH</b>	2	1	1	1	1	3	1	1	3	1	3	1	3	1
Aluminium Sulphate	<b>Al<sub>2</sub>(SO<sub>4</sub>)<sub>3</sub></b>	1	1	1	1	1	1	1	1	1	1	1	1	1	1
Amines	<b>R-NH<sub>2</sub></b>	1	2	1	3	1	---	1	1	3	2	4	1	---	---
Calcium Hydroxide	<b>Ca(OH)<sub>2</sub></b>	1	1	1	1	1	1	1	1	1	1	1	1	1	1
Calcium Hypochlorite	<b>Ca(OCl)<sub>2</sub></b>	1	1	1	1	3	1	1	1	1	1	3	1	2	2
Copper Sulphate	<b>CuSO<sub>4</sub></b>	1	1	1	1	1	1	1	1	1	1	1	1	1	1
Ferric Chloride	<b>FeCl<sub>3</sub></b>	1	1	1	1	3	1	1	1	1	1	1	1	1	2
Hydrofluoric Acid 40%	<b>HF</b>	3	1	1	2	3	3	2	1	1	3	3	1	3	3
Hydrochloric Acid	<b>HCl</b>	1	1	1	1	3	1	1	1	1	3	3	1	2	2
Hydrogen Peroxide 30%	<b>H<sub>2</sub>O<sub>2</sub></b>	1	1	1	1	1	3	1	1	1	2	3	1	2	1
Nitric Acid 65%	<b>HNO<sub>3</sub></b>	1	1	2	3	2	3	1	1	1	3	3	2	3	3
Phosphoric Acid 50%	<b>H<sub>3</sub>PO<sub>4</sub></b>	1	1	1	1	2	1	1	1	1	1	3	1	2	1
Potassium Permanganate 10%	<b>KMnO<sub>4</sub></b>	1	1	1	1	1	1	1	1	1	1	3	1	---	---
Sodium Bisulphate	<b>NaHSO<sub>3</sub></b>	1	1	1	1	2	1	1	1	1	1	1	1	1	1
Sodium Carbonate	<b>Na<sub>2</sub>CO<sub>3</sub></b>	2	1	1	1	1	1	1	1	2	1	1	1	1	1
Sodium Hydroxide	<b>NaOH</b>	2	1	1	1	1	1	1	1	2	1	2	1	1	2
Sodium Hypochlorite 12,5%	<b>NaOCl+NaCl</b>	1	1	2	1	3	1	1	1	1	1	2	1	1	2
Sulphuric Acid -85%	<b>H<sub>2</sub>SO<sub>4</sub></b>	1	1	1	1	2	3	1	1	1	3	3	1	3	3
Sulphuric Acid -98,5%	<b>H<sub>2</sub>SO<sub>4</sub></b>	1	1	3	3	3	3	1	1	1	3	3	3	3	3

**1 : Resistant**

**2 : Good**

**3 : Non-Resistant**

# Pump Flow Pressure Graphics

## 15 Pump Flow Pressure Graphics

NOVA 25L/5B

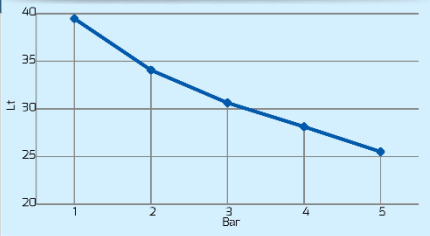

NOVA 10L/10B



NOVA 4L/20B

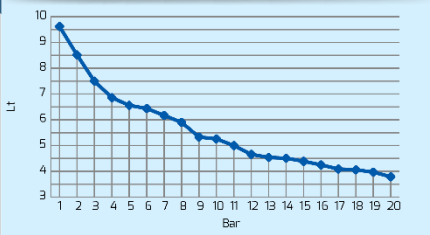

NOVA 4L/7B

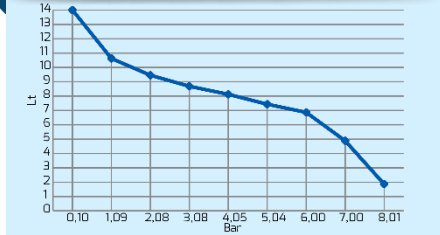

NOVA 12L/4B

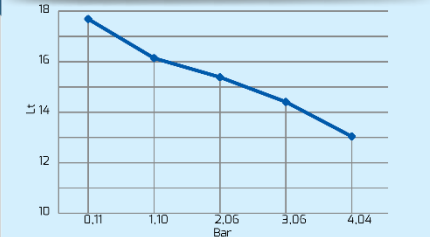

---

## 16 Warranty / Standards

---

### 16.1 Warranty

Dosage Pump is under warranty for 2 years against damages arising from material and manufacturing faults according to legal regulations.

Damages arising from normal wear, overloading or undue usage are not covered by warranty.

Damages from material or manufacturing faults shall be compensated by repairing or replacing faulty part or the device completely.

Claims of warranty shall be accepted only if device is returned to the supplier or authorized service in full shape without disassembly.



#### CAUTION

Warranty Certificate should be filled and approved by the dealer where you buy the device. Please have the certificate stamped by the dealer and keep it.

### 16.2 Standards



TS EN 61000-6-1  
TS EN 61000-6-3  
IEC 60335-2-41  
IEC 60335-1  
EN 60332-41  
EN 60335-1





